

Fabco Power

Setting the Standard in Mobile Power

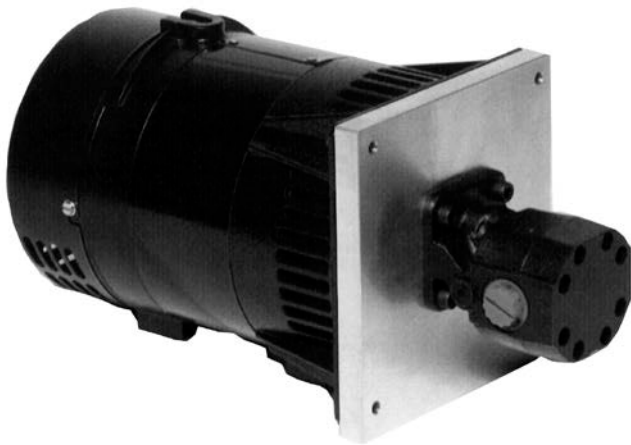

Instruction Manual for Model

HYDRO - 200CX - 4.8 – 50HZ

HYDRAULIC GENERATOR

Manufacturing of: Vehicle Mounted Generators • Hydraulic Generators

P.O. Box 582 • Chester, NY 10918 • 845-469-9151 • Fax: 845-469-7871 • Web Site/E-mail: www.fabcopower.com

GENERAL INFORMATION

MODEL: HYDRO 200CX – 4.8 – 50HZ

GENERATOR..... BRUSHLESS

GENERATOR..... 3000 (50 Hz)

GENERATOR VOLTAGE..... 120 or 120/240

MOTOR STARTING..... 300% SURGE

VOLTAGE REGULATOR..... INHERENT

OUTPUT..... 2000 WATTS CONTINUOUS
2500 WATTS PEAK AT
100°F OIL TEMPERATURE

HYDRAULIC MOTOR..... GEAR TYPE

MAXIMUM SPEED..... 4200RPM
(3000 RPM IDEAL)

MOTOR SHAFT..... 1/2 inch

PORT SIZE

INLET..... S.A.E. # 8

RETURN..... S.A.E. # 10

CASE DRAIN PORT..... S.A.E. # 4

RECOMMENDATIONS

MODEL: HYDRO 200CX-4.8-50HZ

HIGH PRESSURE LINE 1/2 inch

LOW PRESSURE LINE..... 3/4 inch

FLOW RATE 4.8 GPM

*FOR BEST RESULTS KEEP HYDRAULIC OIL
TEMPERATURE BETWEEN 80°F AND 120°F.
DO NOT EXCEED 175°F.*

AN OIL COOLER IS RECOMMENDED.

MAXIMUM BACK PRESSURE 150 PSI

*WILL OPERATE ON ANY 2500 PSI OPEN CIRCUIT
OR CLOSED LOOP SYSTEMS.*

RECOMMEND FILTER 10m

RECOMMEND HYDRAULIC OIL DEXTRON III A.T.F.

INSTALLATION TIPS

Excessive pressure in your return line will damage the hydraulic motor seal. High back pressure can be caused by “spikes” sent back through the return from other equipment on a common return line. Another potential problem can develop if several pieces of equipment are connected to one “common” return line causing a high back pressure (150 PSI is the maximum). We recommend you run the return line from the generator back to the cooling tank with a separate line.

You can either run the 3/4 inch return line back to the tank or leave the 3/4 inch line connected to a common return and run a separate 3/8 inch line from the case drain (located at the bottom of the hydraulic motor) directly back to the tank. Either way you completely eliminate any problem of excessive return line pressure damaging your hydraulic motor.

Initial Installation and Start-Up

Be sure you set the hydraulic flow (GPM) to the generator at Approximately 52.5 HZ or 3150 RPM with NO electrical load on the generator.

By using this setting you will have approximately 50HZ (cycles) or 3000 RPM when you are running at full rated load.

One way this can be accomplished is by using a Photo Tachometer on our generator coupling or generator cooling fan.

A Photo Tachometer is an inexpensive tool that can be purchased at McMasters, Grainger, Sears or any other electrical supplier.

TECHNICAL INFORMATION

These self-excited and self-regulating generators, although overall dimensions have been reduced to a minimum, are designed for high-level electrical performance and the maximum in operating reliability.

PRELIMINARY CHECKS:

Before touching the machines, perform a thorough and in depth visual inspection, checking that components are correctly connected up and that no cables or terminals are broken or loose.

STARTING UP:

Make sure, when starting up, that cooling air intake and discharge openings are free and unblocked. We also recommend (when the machine operates in a dusty environment) do periodic checks to make sure it is properly ventilated

THE IMPORTANCE OF SPEED:

Frequency and voltage depend directly on rotation speed. This must be kept as constantly as possible on its nominal value no matter what the load. Drive motor speed control systems generally have a small drop in speed between no load and loaded conditions. We therefore recommend setting no load speed 3-4% above nominal speed.

CHECKING VOLTAGE:

All the machines are regulated during factory testing. If voltage readings differ from the value indicated on the name plate, this maybe caused by a mistaken reading or by a different rotation speed and we recommend regulating motor speed in order to have nominal RPM under loaded conditions.

CHECKING THE DIODES:

For the ohmmeter test it is best to disconnect the diode from its circuit. Measure continuity in one direction only. The test can also be made without disconnecting the diode from the circuit, using a 12V battery and a 45 watt light bulb (automobile light) as shown in the illustration. The light should turn totally on only in one direction, as shown below.

**WINDING RESISTANCE AT 20° C
ROOM TEMPERATURE**

<u>Size</u>	<u>Stator Ω</u>	<u>Rotor Ω</u>	<u>Exciter Ω</u>
3.5	0.7	9.22	4.0
4.0	0.7	9.28	4.0
5.0	0.54	2.97	2.24
6.0	0.54	2.97	2.24
8.0	0.49	2.85	4.41
12.0	0.250	5.65	0.60
2.0 50 HZ	0.733	3.51	4.60
2.0	0.570	3.51	3.129

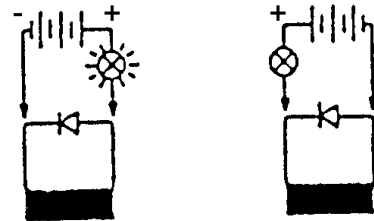

TROUBLE SHOOTING

PROBLEMS	CAUSES	REMEDIES
ALTERNATOR EXCITATION FAILURE	<ol style="list-style-type: none"> 1. Low Speed 2. Faulty capacitor 3. Faulty winding 	<ol style="list-style-type: none"> 1. Check RPM and set at nominal value. 2. Check and replace. 3. Check that winding resistance is as shown in the tables.
HIGH NO-LOAD VOLTAGE	<ol style="list-style-type: none"> 1. Speed too high. 2. Capacitor with high capacity. 	<ol style="list-style-type: none"> 1. Check and adjust RPM's 2. Check and replace
LOW NO-LOAD VOLTAGE	<ol style="list-style-type: none"> 1. Speed too low. 2. Faulty rotary diodes. 3. Breakdown in windings. 4. Capacitor with high capacity. 	<ol style="list-style-type: none"> 1. Check and adjust RPM's 2. Check and replace. 3. Check winding resistance, as per tables. 4. Check and replace.
PROPER NO-LOAD BUT LOW LOADED VOLTAGE	<ol style="list-style-type: none"> 1. Low loaded speed. 2. Load too large. 3. Rotary diodes short-circuited 	<ol style="list-style-type: none"> 1. Check and regulate RPM. 2. Check and change. 3. Check and replace.
UNSTABLE VOLTAGE	<ol style="list-style-type: none"> 1. Loose contacts. 2. Uneven rotation. 	<ol style="list-style-type: none"> 1. Check connections. 2. Check for uniform rotation speed.
NOISY GENERATOR	<ol style="list-style-type: none"> 1. Broken bearings. 2. Poor couplings. 	<ol style="list-style-type: none"> 1. Replace. 2. Check and repair.

PARTS BREAKDOWN

HYDO 200CX-4.8-50HZ

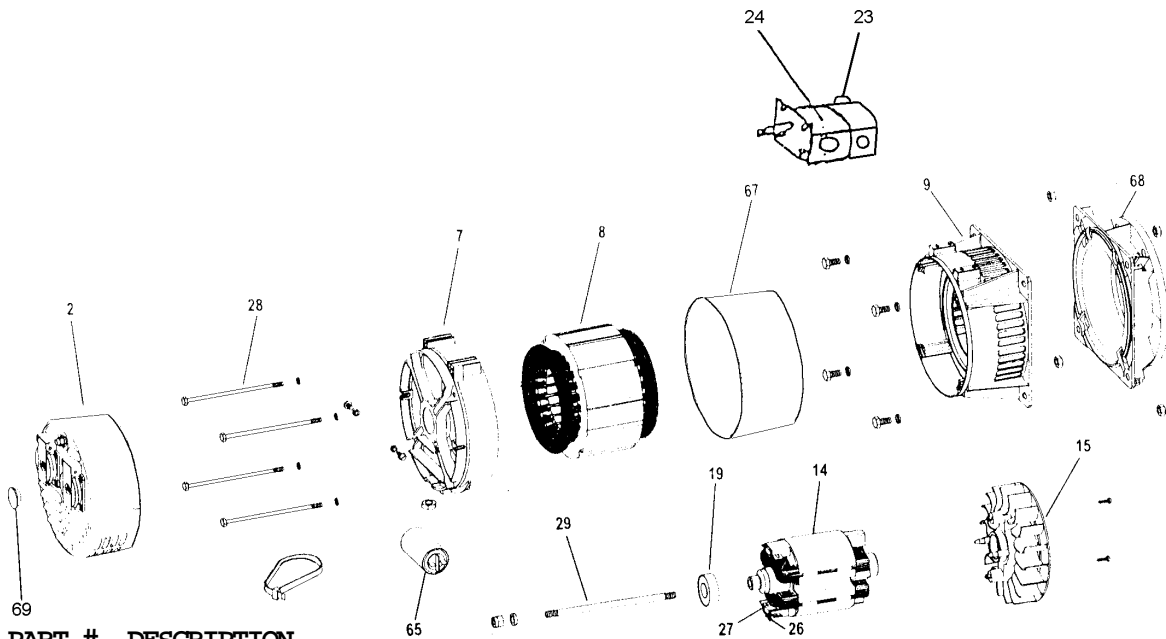

<u>No.</u>	<u>PART #</u>	<u>DESCRIPTION</u>
2	572325	Rear End Cover
7	572326	Rear End Casting
8	572586	Stator
9	572238	Drive End Casting
14	572585	Rotor
15	572330	Fan
19	572064	Rear Bearing
20	572154	Rubber Mounts
23	572206	Flow Control Cartridge
24	572324	Hyd.Motor
25	572128	Mounting Rails
26	572331	Diodes
27	572332	Varister
28	572333	Studs
29	572334	Thru Bolt
65	572062	Capacitor (20 MFD)
67	572335	Band
68	572309	Face Plate
69	572053	Power Cord
	572310	Stub Shaft
	572578	Complete Generator
	572309	Alum. Mounting Plate
	572581	16 Amp Circuit Breaker
	572580	8 Amp Circuit Breaker
	572363	Seal Kit

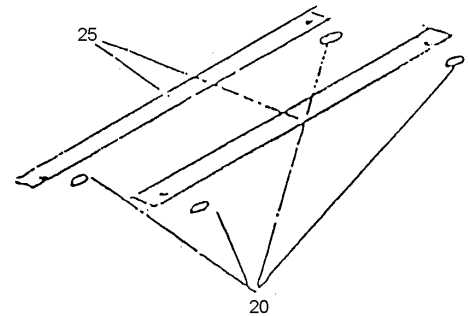

HYDRAULIC MOTOR

HOSE HOOK-UP

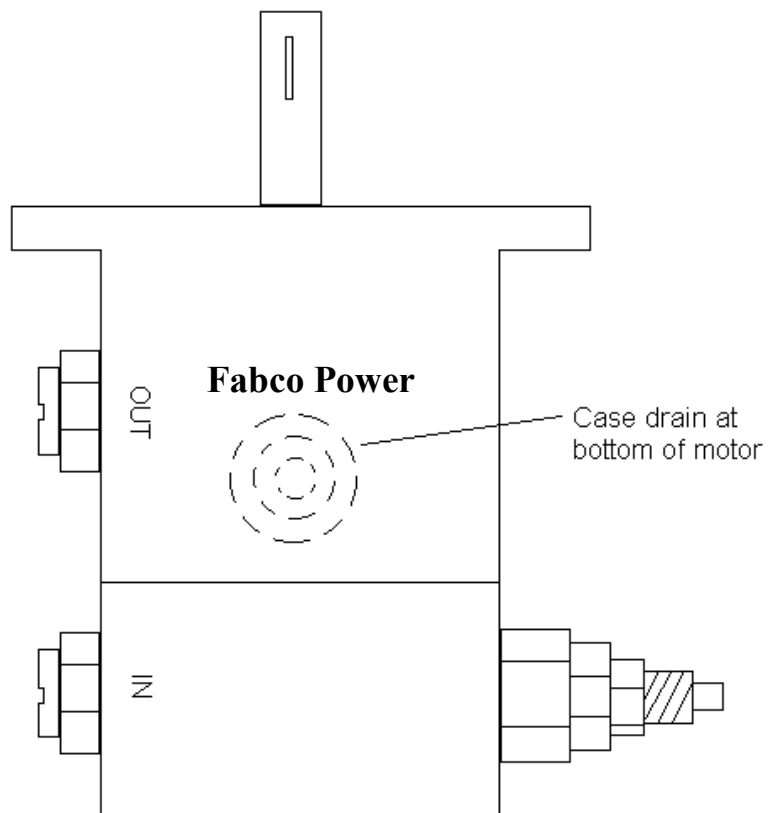

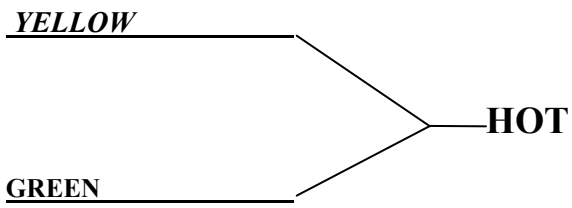

120 VOLT

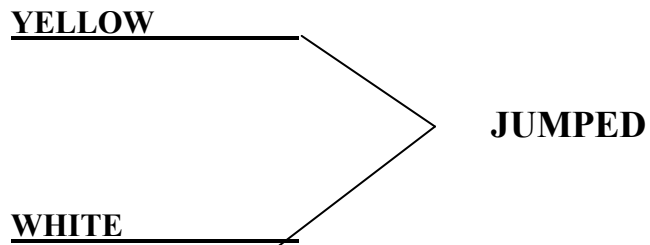
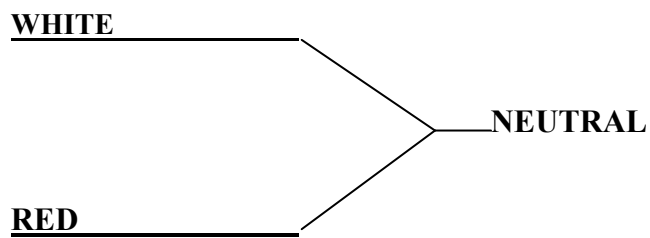

GREEN

240 VOLT

RED