



Setting the Standard in Mobile Power

Instruction Manual for Model

HYDRO ARC 7500

Hydraulic Generator/Welder

SINGLE WIRE 220 VOLT

Manufacturing of: Vehicle Mounted Generators • Hydraulic Generators

P.O. Box 582 • Chester, NY 10918 • 845-469-9151 • Fax: 845-469-7871 • Web Site: www.fabcopower.com

CAUTION

CAUTION

DO NOT RUN

WELDER/GENERATOR

WITH (OPTIONAL)

**WATERPROOF CANVAS
COVER**

CANVAS COVER MUST BE

REMOVED.... THANK YOU

Initial Installation and Start-Up

Be sure you set the hydraulic flow (GPM) to the generator at Approximately 62.5 HZ or 3750 RPM with NO electrical load on the generator.

By using this setting you will have approximately 60HZ (cycles) or 3600 RPM when you are running at full rated load.

One way this can be accomplished is by using a Photo Tachometer on our generator coupling or generator cooling fan.

A Photo Tachometer is an inexpensive tool that can be purchased at McMasters, Grainger, Sears or any other electrical supplier.

HYDRO-ARC-7500 WELDER/GENERATOR

TECHNICAL INFORMATION AND SPECIFICATIONS

BEFORE INSTALLING YOUR NEW HYDRO-ARC-7500 WELDER/GENERATOR PLEASE READ THE FOLLOWING SPECIFICATIONS

1. THE HYDRO-ARC-7500 IS A COMBINATION OF A DC WELDER OR AN AC GENERATOR RATED AT 7500-WATTS (7.5 KW) PEAK, (6 KW) CONTINUOUS, AC, 60 HZ, AT 3600 RPM 110 / 220 VOLTS AC AND (6.0 KW) DC FOR WELDING OR 240 AMPS DC PEAK.

2. THE AC PORTION OF THE GENERATOR MUST BE SWITCHED TO AC BY TURNING THE TWO POSITION ROTARY SWITCH ON THE CONTROL PANEL TO THE LEFT TO THE GEN-POSITION SHOWING AN ICON OF A LIGHT BULB. THE AC GENERATOR IS PROTECTED BY CIRCUIT BREAKERS LOCATED ON THE FRONT PANEL FOR BOTH 120VAC AND 240VAC OPERATION AT 7.5 KW.

DO NOT TRY TO WELD WHEN THE SWITCH IS IN THE GEN-POSITION!

3. THE WELDING OR DC PORTION OF THE GENERATOR MUST BE SWITCHED TO THE WELD-POSITION BY TURNING THE TWO POSITION ROTARY SWITCH TO THE RIGHT TO THE WELD POSITION. WHEN USED AS A WELDER ALONE THE AC PORTION OF THE GENERATOR WILL NOT GENERATE AC VOLTAGE.

4. WHEN CONNECTING THE WELDING LEADS CONNECT THE POSITIVE LEAD HOLDING THE WELDING ROD TO THE CONNECTOR ON THE LEFT SIDE OF THE CONTROL PANEL MARKED WITH +. CONNECT THE NEGATIVE LEAD OR GROUND CLAMP TO THE CONNECTOR ON THE RIGHT SIDE OF THE CONTROL PANEL MARKED

5. SET THE MIN/MAX TOGGLE SWITCH TO MIN FIRST THEN ROTATE THE SEVEN POSITION ROTARY SWITCH TO THE DESIRED AMP SETTING FROM 40 TO 135 AMP PRE-SET HEAT SETTINGS. WHEN MORE POWER IS NEEDED SET THE ROTARY TO ITS LOWEST POSITION THEN SET THE MIN/MAX TOGGLE SWITCH TO MAX. TRY TO WELD AT THE 140 AMP POSITION AND INCREASE AS NEEDED TO 240 AMPS DC.

CAUTION ONLY USE THE DC WELDING PORTION OF THE GENERATOR FOR WELDING APPLICATIONS, USING WELDING RODS APPLICABLE TO NORMAL WELDING CONDITIONS.

GENERAL INFORMATION AND SPECIFICATIONS
HYDRO-ARC-7500 DC WELDER AC GENERATOR

GENERATOR DC / AC 60 HZ, SPEED = ...3600 RPM

GENERATOR VOLTAGE..... 110 / 220

MOTOR STARTING SURGE ...= 300% OF CONTINUOUS

OUTPUT.....6,000 WATTS CONTINUOUS AC OR DC
7,500 WATTS PEAK AC

AC AMPS @ 220 VOLT = 32 PEAK AND 25 CONTINUOUS

AC AMPS @ 110 VOLT = 62 PEAK AND 50 CONTINUOUS

DC WELDING AMPS = 240 PEAK AND 140 CONTINUOUS

HYDRAULIC MOTOR SPECIFICATIONS

AXIAL PISTON TYPE11 cc DISPLACEMENT

MOTOR SHAFT DIAMETER.....ONE INCH

FLOW CONTROL (OPTIONAL)...CARTRIDGE TYPE

RATED FLOW = 11.6 GPM RATED PSI = 2,400

MOTOR SPEED = 3,600 RPM..... MAXIMUM = 4,200 RPM

INLET PORT SIZE = 1 & 1/16 – 12 S.A.E

RETURN PORT SIZE = 1 & 1/16 – 12 S.A.E

CASE DRAIN PORT SIZE = 1 & 1/16 – 12 S.A.E

SH 7/13/11

TECHNICAL INFORMATION

These self-excited and self-regulating generators, although overall dimensions have been reduced to a minimum, are designed for high-level electrical performance and the maximum in operating reliability.

PRELIMINARY CHECKS:

Before touching the machines, perform a thorough and in depth visual inspection, checking that components are correctly connected up and that no cables or terminals are broken or loose.

STARTING UP:

Make sure, when starting up, that cooling air intake and discharge openings are free and unblocked. We also recommend (when the machine operates in a dusty environment) do periodic checks to make sure it is properly ventilated

THE IMPORTANCE OF SPEED:

Frequency and voltage depend directly on rotation speed. This must be kept as constantly as possible on its nominal value no matter what the load. Drive motor speed control systems generally have a small drop in speed between no load and loaded conditions. We therefore recommend setting no load speed 3=4% above nominal speed.

CHECKING VOLTAGE:

All the machines are regulated during factory testing. If voltage readings differ from the value indicated on the name plate, this maybe caused by a mistaken reading or by a different rotation speed and we recommend regulating motor speed in order to have nominal RPM under loaded conditions.

CHECKING THE DIODES:

For the ohmmeter test it is best to disconnect the diode from its circuit. Measure continuity in one direction only. The test can also be made without disconnecting the diode form the circuit, using a 12V battery and a 45 watt light bulb (automobile light) as shown in the illustration. The light should turn totally on only in one direction, as shown below.

WINDING RESISTANCE AT 20° C ROOM TEMPERATURE			
<u>Size</u>	<u>Stator Ω</u>	<u>Rotor Ω</u>	<u>Exciter Ω</u>
WELDER			
7.5	0.30	9.18	0.295
WELDER WINDING = 0.018			

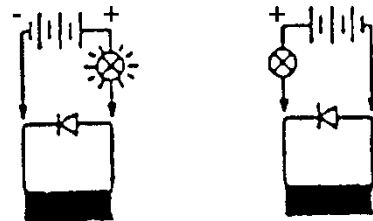

PARTS DRAWING HYDRO ARC 7500

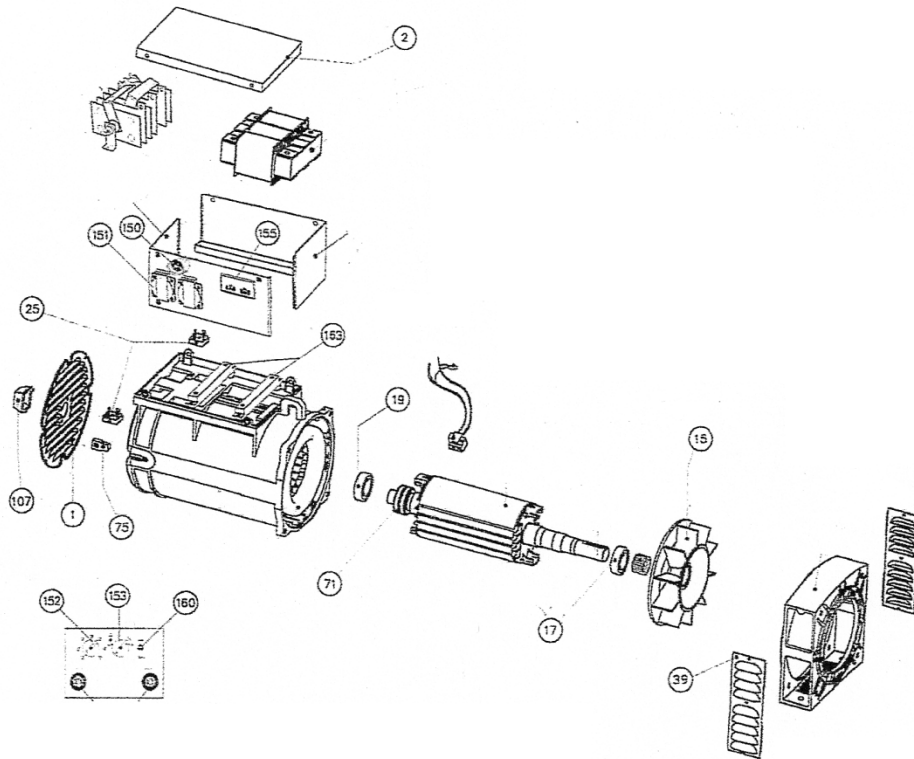

PARTS BREAKDOWN HYDRO ARC 7500

Single wire 220 volt

<u>DAW#</u>	<u>PART #</u>	<u>DESCRIPTION</u>
1	572416	Louvered Panel Back
2	572417	Top Cover
	572564	Front Panel
25	572385	4 Terminal Diode Bridge
25	572386	5 Terminal Diode Bridge
9B	572420	Drive End Bell
17	572423	Front Bearing
15	572422	Fan
19	572424	Rear Bearing
	572065	Channel
	572281	Coupling 28mm LO99
	572282	Spider
	572476	Coupling 1" LO99
	572311	Motor 11CC Piston
	572303	Rails
	572233	Flow Control Assy. 11.5 G.P.M. (opt).
	572240	Flow Control Cartridge only (opt).
	572565	Generator only
39	572218	Coupling Guard
160	572375	Toggle Switch
153	572566	Selector Switch Gen/Weld
151		Removed for this unit
151B		Receptacle 220 Twist Lock
150	572357	Overload Push Button 25 Amp
152	572567	Selector Switch DC Amps

TROUBLE SHOOTING

PROBLEMS	CAUSES	REMEDIES
ALTERNATOR EXCITATION FAILURE	<ol style="list-style-type: none"> 1. Low Speed 2. Faulty winding 	<ol style="list-style-type: none"> 1. Check RPM and set at nominal value. 2. Check that winding resistance is as shown in the tables.
HIGH NO-LOAD VOLTAGE	<ol style="list-style-type: none"> 1. Speed too high. 	<ol style="list-style-type: none"> 1. Check and adjust RPM's
LOW NO-LOAD VOLTAGE	<ol style="list-style-type: none"> 1. Speed too low. 2. Faulty rotary diodes. 3. Breakdown in windings. 	<ol style="list-style-type: none"> 1. Check and adjust RPM's 2. Check and replace. 3. Check winding resistance, as per tables.
PROPER NO-LOAD BUT LOW LOADED VOLTAGE	<ol style="list-style-type: none"> 1. Low loaded speed. 2. Load too large. 3. Diodes short-circuited 	<ol style="list-style-type: none"> 1. Check and regulate RPM. 2. Check and change. 3. Check and replace.
UNSTABLE VOLTAGE	<ol style="list-style-type: none"> 1. Loose contacts. 2. Uneven rotation. 	<ol style="list-style-type: none"> 1. Check connections. 2. Check for uniform rotation speed.
NOISY GENERATOR	<ol style="list-style-type: none"> 1. Broken bearings. 2. Poor couplings. 	<ol style="list-style-type: none"> 1. Replace. 2. Check and repair.

FIXED DISPLACEMENT **TYPE PUMP**

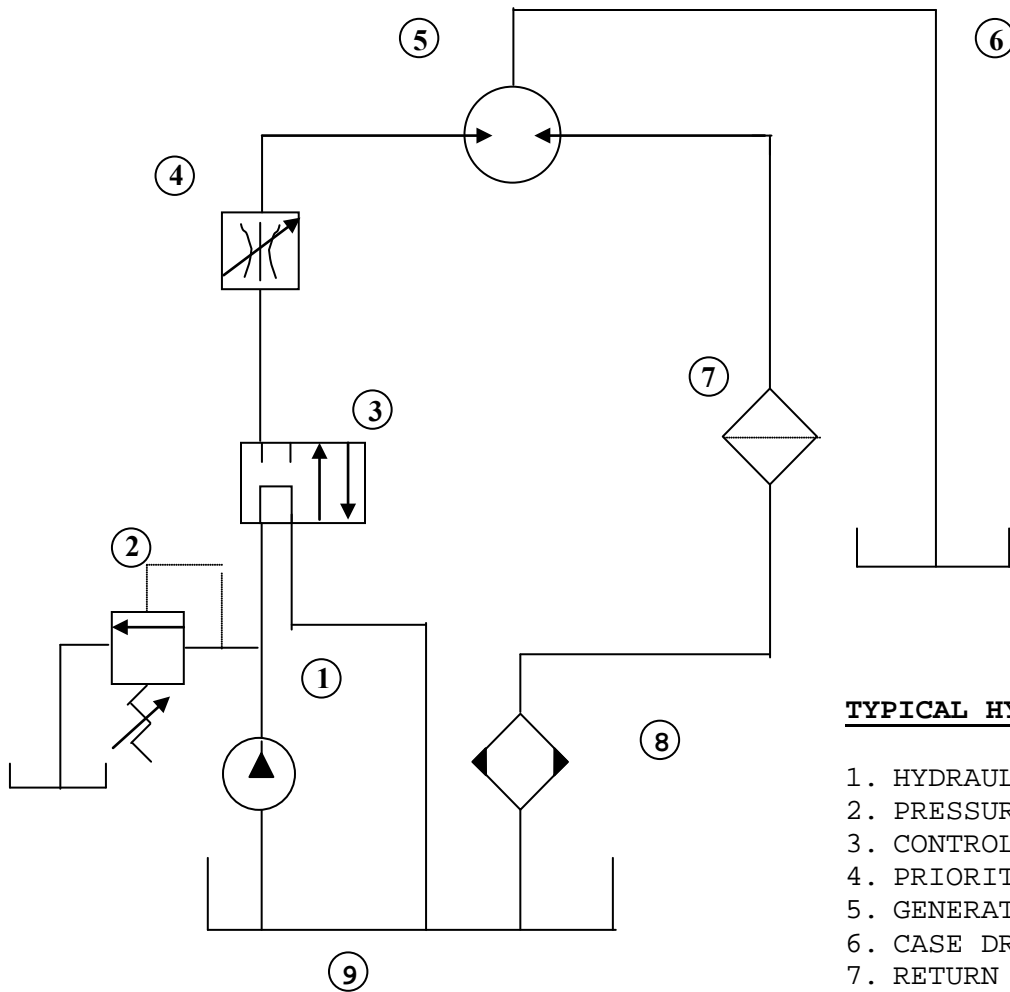

TYPICAL HYDRAULIC SCHEMATIC

1. HYDRAULIC PUMP
2. PRESSURE RELIEF VALVE
3. CONTROL VALVE
4. PRIORITY FLOW CONTROL*
5. GENERATOR HYRAULIC MOTOR
6. CASE DRAIN LINE**
7. RETURN LINE FILTER
8. OIL COOLER
9. HYDRAULIC FLUID RESERVOIR

* Some units may be equipped with integral priority flow control, refer to specific model number.

** External case drain line may be required on some units refer to specific model number.
When external case drain is required it should be unobstructed direct return to reservoir with a minimum I.D. no less than that of case drain port on generator motor.

FOR SPECIFIC INSTALLATION RECOMMENDATIONS CONSULT FACTORY

Hydro-Arc 7500

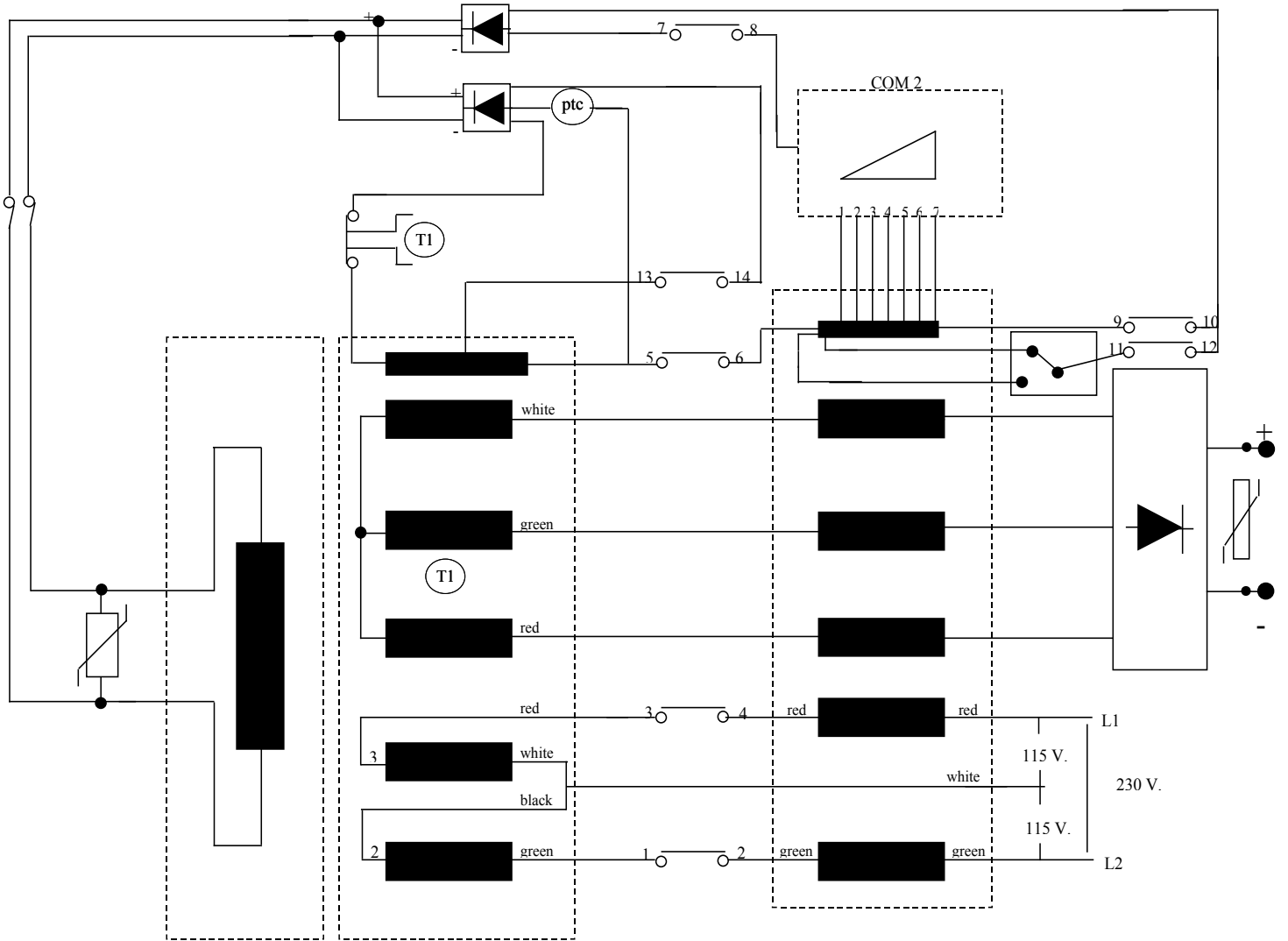

FABCO BY-PASS FLOW CONTROL

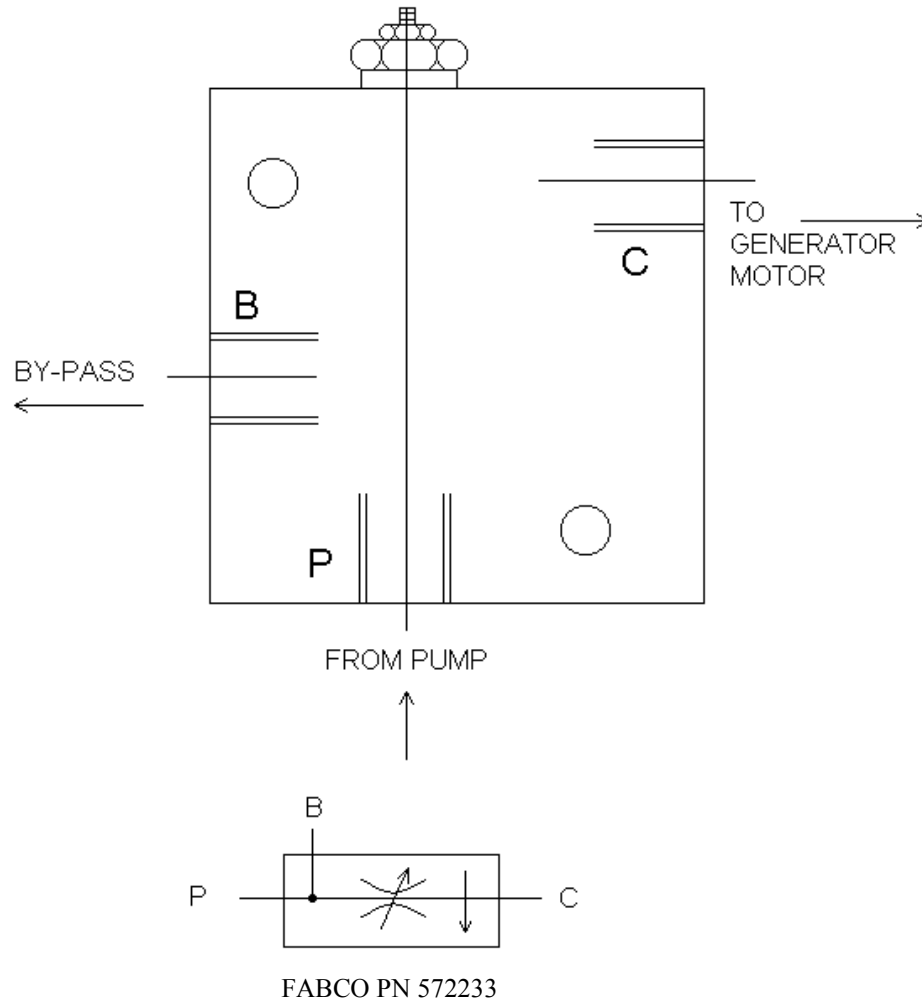

**NOTE: THIS ASSEMBLY ONLY NEEDED
WITH FIXED DISPLACEMENT TYPE
GEAR PUMP.**

REVISIONS		
LTR	DESCRIPTION	DATE

TYPICAL HYDRAULIC SCHEMATIC

PISTON TYPE, LOAD SENSING

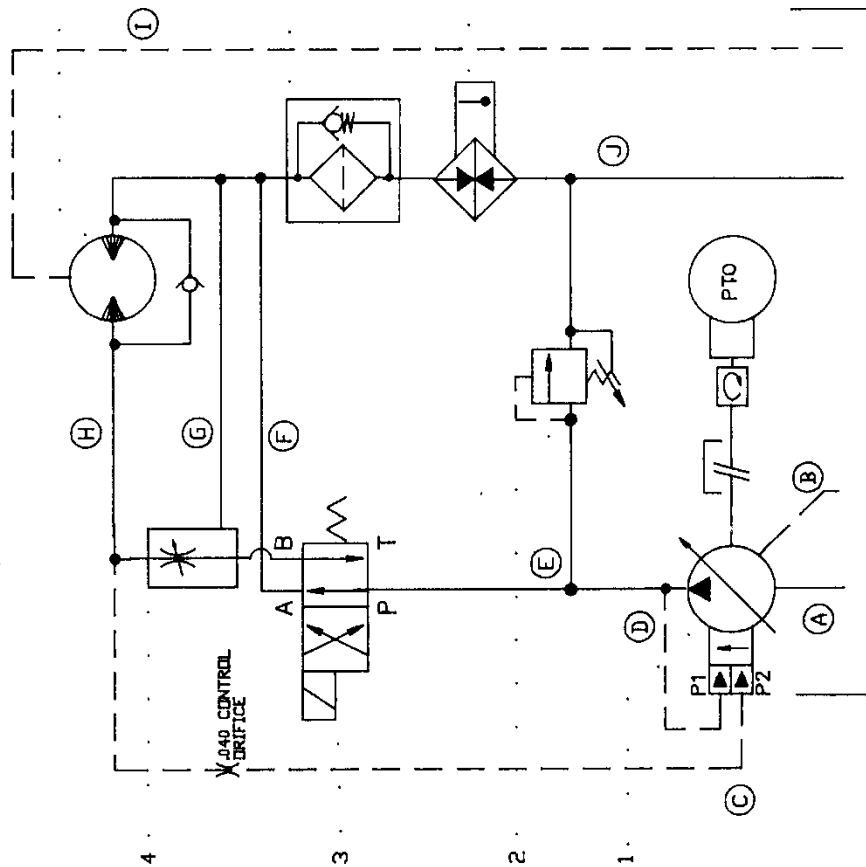

ITEM	QTY	ITEM	DESCRIPTION
1	1	HYDRAULIC PUMP	PISTON TYPE V/LOAD SENSE
2	1	RELIEF VALVE	SET AT 3000 PSI
3	1	DIRECTIONAL VALVE	(SEE NOTE 'A')
4	1	FLOW CONTROL	(SEE NOTE 'A')
5	1	HYDRAULIC MOTOR	WITH EXTERNAL CASE DRAIN
6	1	FILTER	RETURN LINE V/BYPASS
7	1	HEAT EXCHANGER	
8	1	HYDRAULIC RESERVOIR	

CUSTOMER CONNECTIONS & LINE SIZES	
DES	DESCRIPTION
A	1-1/4" SUCTION LINE
B	3/8" PUMP CASE DRAIN
C	1/4" EXTERNAL SENSE LINE
D	N/A INTERNAL SENSE LINE
E	1" MAIN SUPPLY LINE
F	3/4" PRESSURE LINE
G	3/4" PRESSURE LINE
H	3/4" PRESSURE LINE
I	3/8" MOTOR CASE DRAIN
J	1" RETURN LINE

* * * * *
* * * * *
* * * * *
* * * * *

REQUIRED ON SOME MODELS. REFER TO SPECIFIC MODEL NUMBER.

NOTE "A"

SUPPLIED ON SOME MODELS. REFER TO SPECIFIC MODEL NUMBER.

FOR SPECIFIC INSTALLATION
RECOMMENDATIONS CONSULT
FACTORY

F A B C O P O W E R

CHESTER, N.Y.

MAX FLOW: _____ DATE _____
MAX PRESSURE: _____ TITLE: _____

FABCO POWER'S HYDRO-ARC-7500

220 VOLT AC 32 AMP

3 WIRE TWIST LOCKING OUTLET

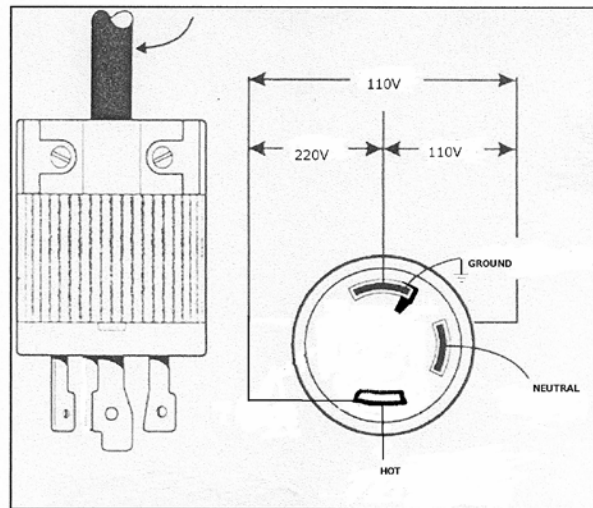

To connect power to the 110/220 volt single phase outlet mounted on the front panel of the generator, use a 30 AMP 250V NEMA - L6-30, MALE TWIST LOCKING PLUG.

Connect a 3-WIRE cord set rated at 250 volts at 30 Amps AC or greater. The wiring shown above can be connected to a standard 110/220 volt circuit breaker box or directly to a 110/220 volt load.

The peak generator output is rated at 30 Amps AC at 240 volts. An automatic resetting overload protection device set for 25 Amps is incorporated in the generator controls.

sh 7/13/11

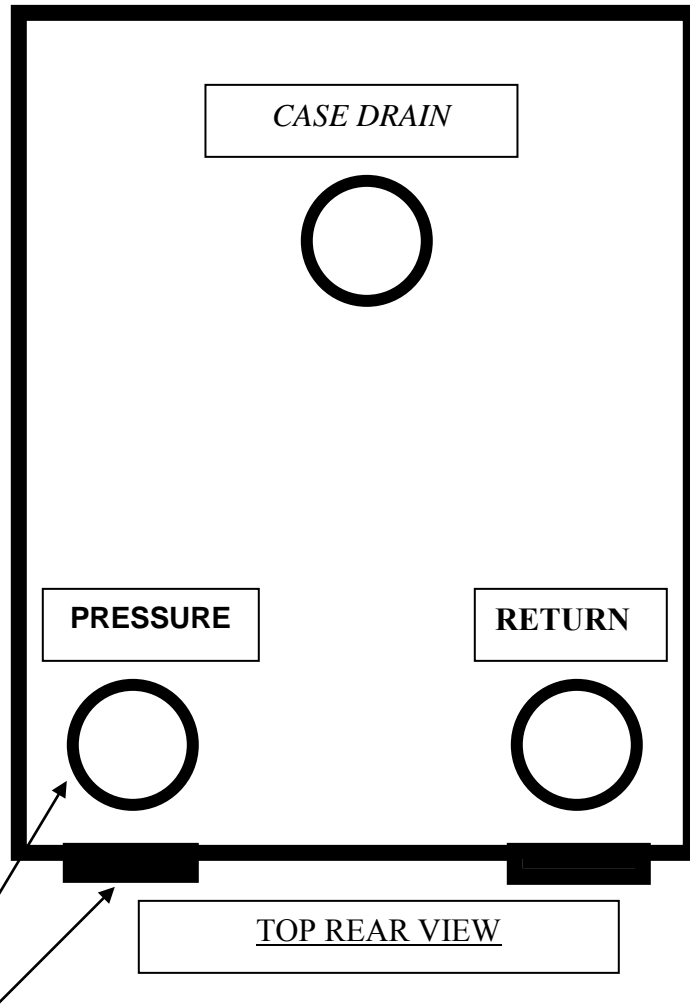

NOTE: THE **PRESSURE** AND **RETURN** PORTS CAN BE USED ON THE TOP OR THE REAR OF THE MOTOR BY EXCHANGING THE CAPPED PLUG FITTINGS.

11 cc PISTON MOTOR ALL FITTINGS ARE # 12 SAE