

Fabco Power



Setting the Standard in Mobile Power

Instruction Manual for Model

HYDRO

20 KEP-21

Hydraulic Generator

Manufacturing of: Vehicle Mounted Generators • Hydraulic Generators

P.O. Box 582 • Chester, NY 10918 • 845-469-9151 • Fax: 845-469-7871 • Web Site: www.fabcopower.com

GENERAL INFORMATION

MODEL: HYDRO 20KEP-21

GENERATOR..... BRUSHLESS

GENERATOR..... 3600 (60 Hz)

GENERATOR VOLTAGE..... 120 or 120/240

GENERATOR AMPS 167/84

MOTOR STARTING..... 300% SURGE

VOLTAGE REGULATOR..... INHERENT

OUTPUT..... 20 KW CONTINUOUS

AT 100° F OIL TEMPERATURE

HYDRAULIC MOTOR..... AXIAL PISTON TYPE

FLOW CONTROL (OPTIONAL)..... CARTRIDGE TYPE

MAXIMUM SPEED..... 4200 RPM
(3600 RPM IDEAL)

MOTOR SHAFT..... . 1"

CONTINUOUS
PRESSURE RATING..... 3000 PSI

PORT SIZE

INLET..... 1 1/16 - 12 S.A.E.

RETURN..... 1 1/16 -12 S.A.E.

CASE DRAIN..... 1 1/16 -12 S.A.E.

WEIGHT... 190lbs

DIMENSIONS... 30 1/2"L 10 1/2"W 13"H

RECOMMENDATIONS

MODEL: HYDRO 20KEP-21

HIGH PRESSURE LINE 3/4 inch

LOW PRESSURE LINE..... 1 inch

CASE DRAIN..... 1/2 inch

FLOW CONTROL..... 22 GPM IDEAL

DO NOT EXCEED 175°F. HYDRAULIC OIL TEMPERATURE, FOR BEST RESULTS KEEP OIL TEMPERATURE BELOW 120°F. AN OIL COOLER IS RECOMMENDED.

MAXIMUM BACK PRESSURE 150 PSI

OPEN CENTER 2500 PSI SYSTEMS.

RECOMMEND FILTER 10m

RECOMMEND HYDRAULIC OIL DEXTRON III A.T.F.

RECOMMEND RESERVOIR SIZE MINIMUM 50 GAL.

INSTALLATION TIPS

If our hydraulic generator is to be used on a truck or system that will be changing speeds, such as, in a fire truck (pumping water) we suggest you use a load sensing piston type pump rather than a fixed displacement gear type. The system will run much cooler and more efficient.

Initial Installation and Start-Up

Be sure you set the hydraulic flow (GPM) to the generator at Approximately 62.5 HZ or 3750 RPM with NO electrical load on the generator.

By using this setting you will have approximately 60HZ (cycles) or 3600 RPM when you are running at full rated load.

One way this can be accomplished is by using a Photo Tachometer on our generator coupling or generator cooling fan.

A Photo Tachometer is an inexpensive tool that can be purchased at McMasters, Grainger, Sears or any other electrical supplier.

TECHNICAL INFORMATION

These self-excited and self-regulating generators, although overall dimensions have been reduced to a minimum, are designed for high-level electrical performance and the maximum in operating reliability.

PRELIMINARY CHECKS:

Before touching the machines, perform a thorough and in depth visual inspection, checking that components are correctly connected up and that no cables or terminals are broken or loose.

STARTING UP:

Make sure, when starting up, that cooling air intake and discharge openings are free and unblocked. We also recommend (when the machine operates in a dusty environment) do periodic checks to make sure it is properly ventilated

THE IMPORTANCE OF SPEED:

Frequency and voltage depend directly on rotation speed. This must be kept as constantly as possible on its nominal value no matter what the load. Drive motor speed control systems generally have a small drop in speed between no load and loaded conditions. We therefore recommend setting no load speed 3-4% above nominal speed.

CHECKING VOLTAGE:

All the machines are regulated during factory testing. If voltage readings differ from the value indicated on the name plate, this may be caused by a mistaken reading or by a different rotation speed and we recommend regulating motor speed in order to have nominal RPM under loaded conditions.

CHECKING THE DIODES:

For the ohmmeter test it is best to disconnect the diode from its circuit. Measure continuity in one direction only. The test can also be made without disconnecting the diode from the circuit, using a 12V battery and a 45 watt light bulb (automobile light) as shown in the illustration. The light should turn totally on only in one direction, as shown below.

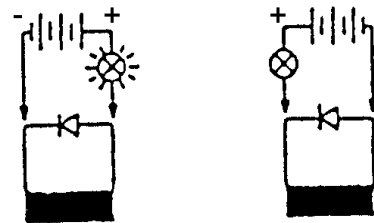

ELECTRICAL CONNECTIONS

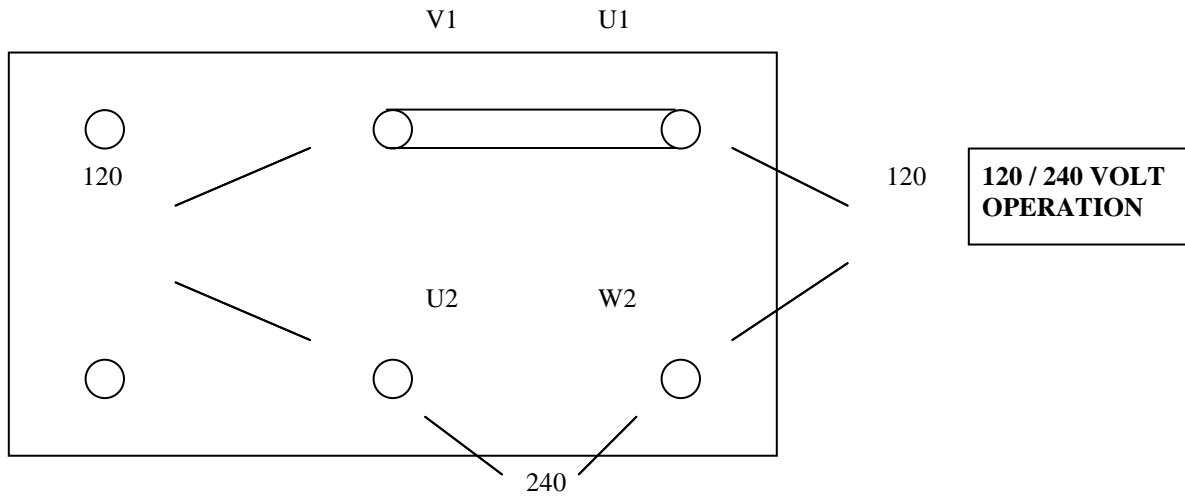

TERMINAL BLOCK

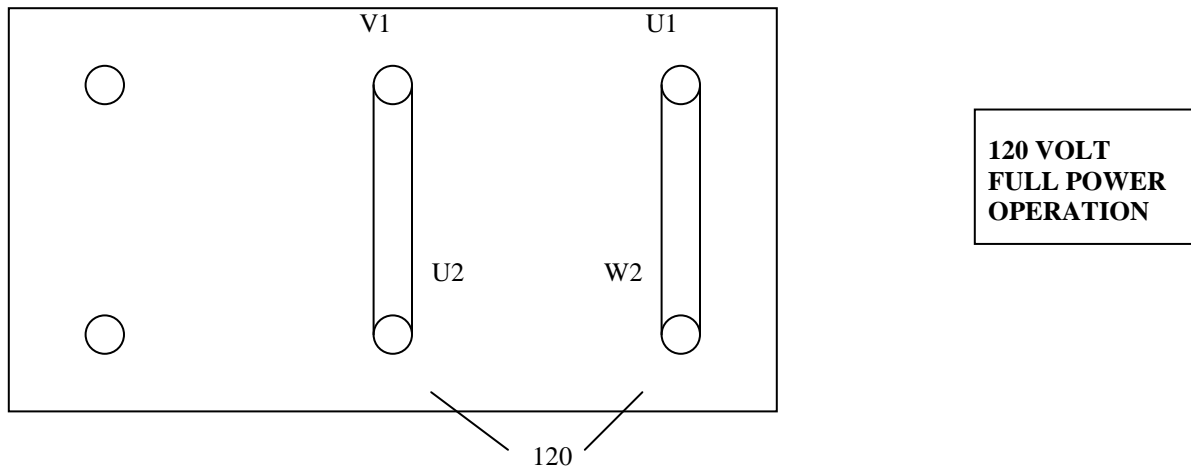

TERMINAL BLOCK

TROUBLE SHOOTING

PROBLEMS	CAUSES	REMEDIES
ALTERNATOR EXCITATION FAILURE	<ol style="list-style-type: none"> 1. Low Speed 2. Faulty capacitor 3. Faulty winding 	<ol style="list-style-type: none"> 1. Check RPM and set at nominal value. 2. Check and replace. 3. Check that winding resistance is as shown in the tables.
HIGH NO-LOAD VOLTAGE	<ol style="list-style-type: none"> 1. Speed too high. 2. Capacitor with high capacity. 	<ol style="list-style-type: none"> 1. Check and adjust RPM's 2. Check and replace
LOW NO-LOAD VOLTAGE	<ol style="list-style-type: none"> 1. Speed too low. 2. Faulty rotary diodes. 3. Breakdown in windings. 4. Capacitor with high capacity. 	<ol style="list-style-type: none"> 1. Check and adjust RPM's 2. Check and replace. 3. Check winding resistance, as per tables. 4. Check and replace.
PROPER NO-LOAD BUT LOW LOADED VOLTAGE	<ol style="list-style-type: none"> 1. Low loaded speed. 2. Load too large. 3. Rotary diodes short-circuited 	<ol style="list-style-type: none"> 1. Check and regulate RPM. 2. Check and change. 3. Check and replace.
UNSTABLE VOLTAGE	<ol style="list-style-type: none"> 1. Loose contacts. 2. Uneven rotation. 	<ol style="list-style-type: none"> 1. Check connections. 2. Check for uniform rotation speed.
NOISY GENERATOR	<ol style="list-style-type: none"> 1. Broken bearings. 2. Poor couplings. 	<ol style="list-style-type: none"> 1. Replace. 2. Check and repair.

FIXED DISPLACEMENT TYPE GEAR PUMP

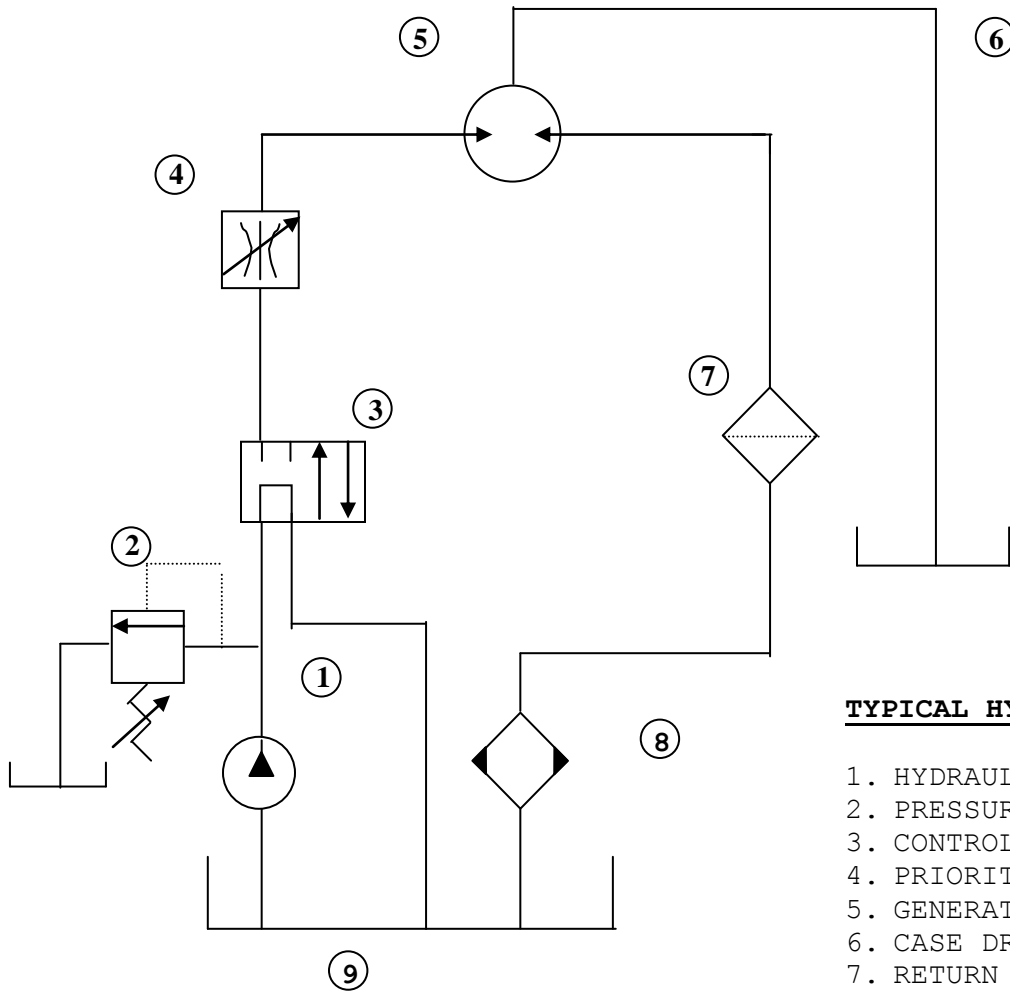

TYPICAL HYDRAULIC SCHEMATIC

1. HYDRAULIC PUMP
2. PRESSURE RELIEF VALVE
3. CONTROL VALVE
4. PRIORITY FLOW CONTROL*
5. GENERATOR HYRAULIC MOTOR
6. CASE DRAIN LINE**
7. RETURN LINE FILTER
8. OIL COOLER
9. HYDRAULIC FLUID RESERVOIR

* Some units may be equipped with integral priority flow control, refer to specific model number.

** External case drain line may be required on some units refer to specific model number.
When external case drain is required it should be unobstructed direct return to reservoir with a minimum I.D. no less than that of case drain port on generator motor.

FOR SPECIFIC INSTALLATION RECOMMENDATIONS CONSULT FACTORY

FABCO BY-PASS FLOW CONTROL

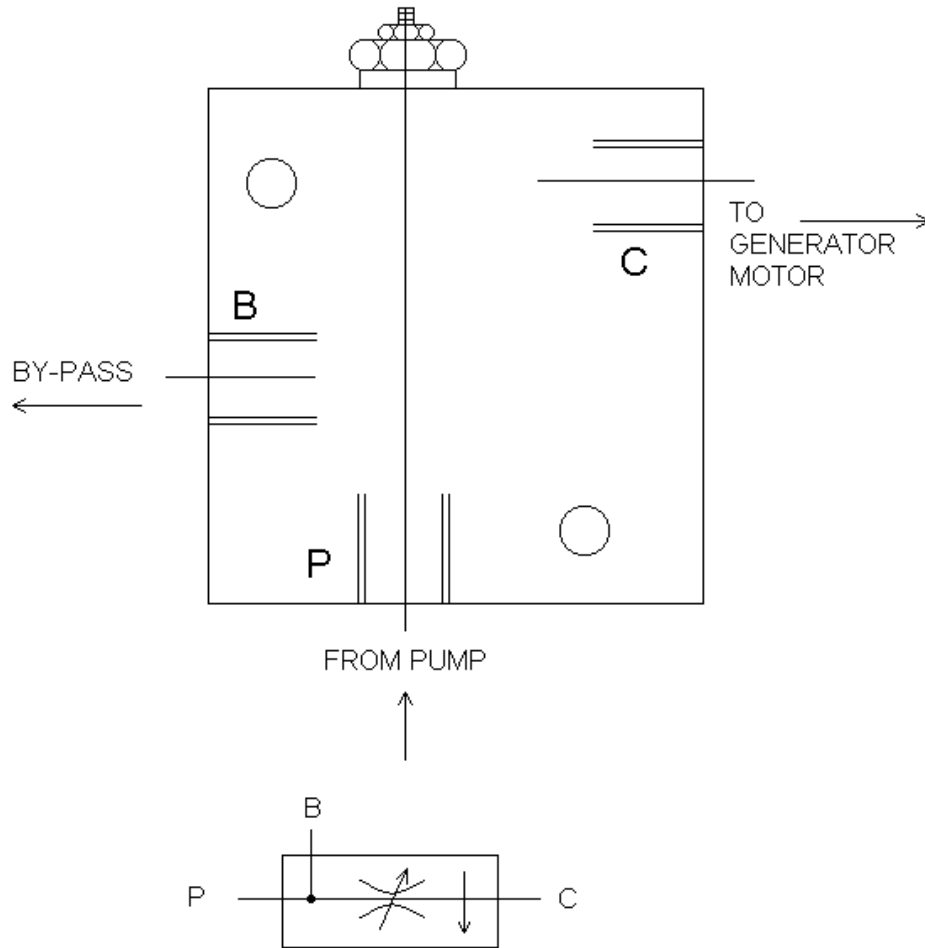

FABCO PN 572233

**NOTE: THIS ASSEMBLY ONLY NEEDED
WITH FIXED DISPLACEMENT TYPE
GEAR PUMP.**

HYDRAULIC MOTOR HOOK-UP

HYDRO 20 KEP

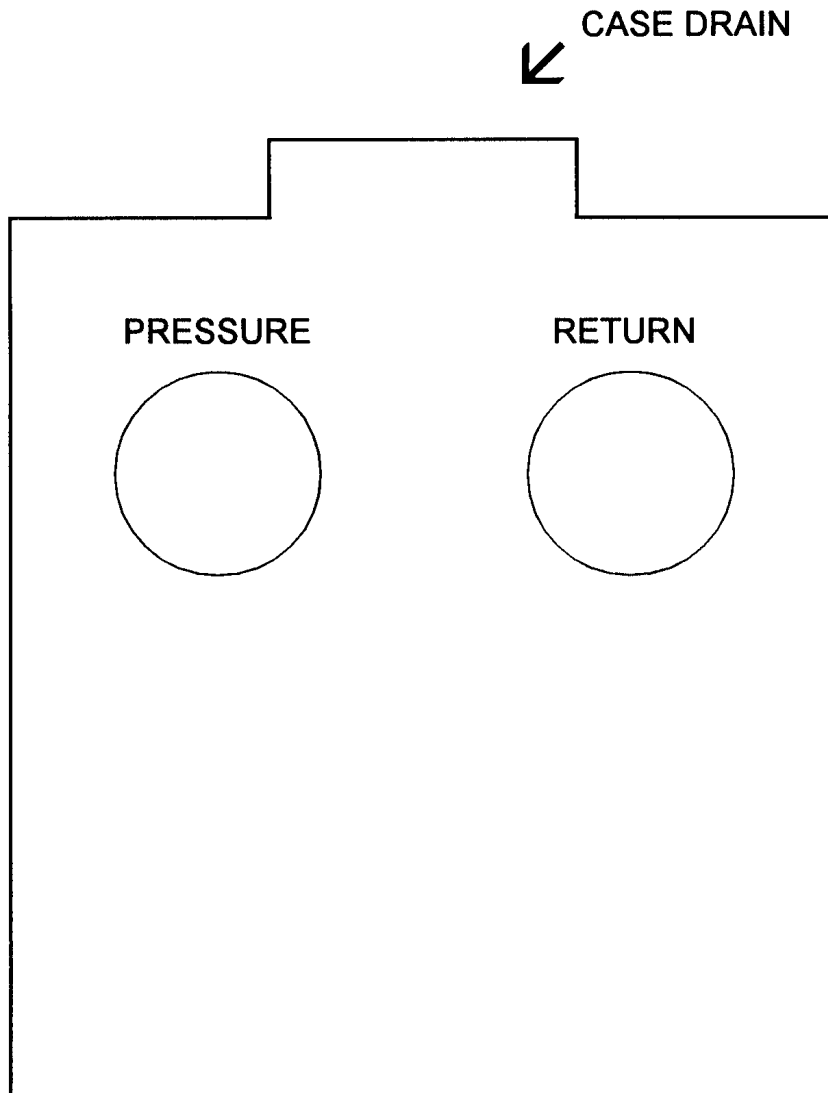

BACK VIEW

Note: Motor supplied with built in anti-cavitation circuit

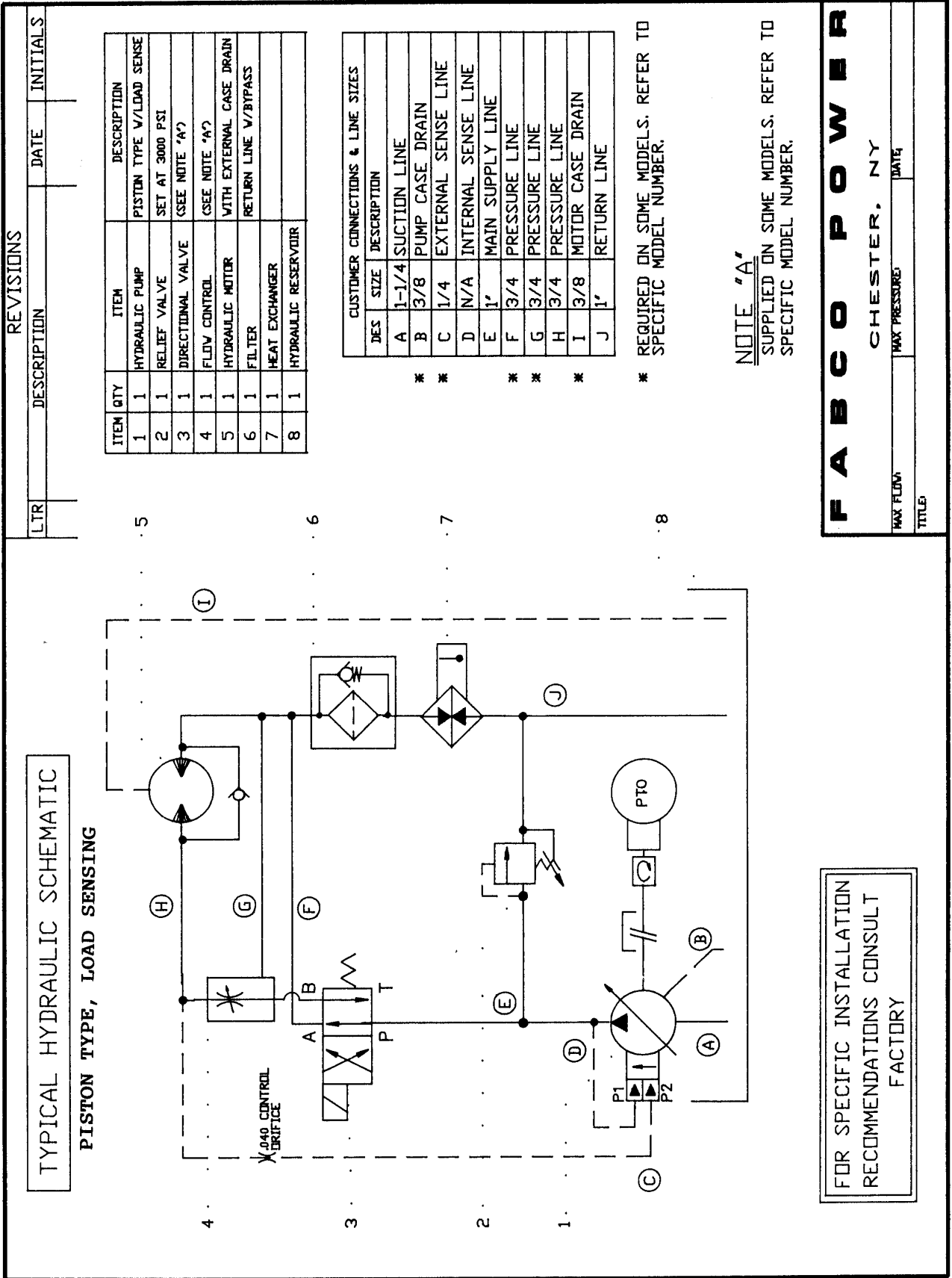

FOR SPECIFIC INSTALLATION
RECOMMENDATIONS CONSULT
FACTORY

F A B C O P O W E R

CHESTER, NY

MAX FLOW: _____ MAX PRESSURE: _____ DATE: _____

TITLE: _____

REVISIONS			
LTR	DESCRIPTION	DATE	INITIALS