



Setting the Standard in Mobile Power

Instruction Manual for Model

HYDRO – 8KCD – 16 - 3

Hydraulic Generator

Manufacturing of: Vehicle Mounted Generators • Hydraulic Generators

P.O. Box 582 • Chester, NY 10918 • 845-469-9151 • Fax: 845-469-7871 • Web Site/E-mail: www.fabcopower.com

GENERAL INFORMATION

MODEL: HYDRO 8KCD – 16 - 3

GENERATOR.....	BRUSHLESS – 3 PHASE
GENERATOR.....	3600 (60 Hz)
GENERATOR VOLTAGE.....	120 or 120/208
MOTOR STARTING.....	300% SURGE
VOLTAGE REGULATOR.....	INHERENT
OUTPUT.....	8000 WATTS CONTINUOUS 8500 WATTS PEAK AT 100° F OIL TEMPERATURE
HYDRAULIC MOTOR.....	GEAR TYPE WITH CASE DRAIN PRESSURED BALANCE
FLOW CONTROL (OPTIONAL).....	CARTRIDGE TYPE
MAXIMUM SPEED.....	4200RPM (3600 RPM IDEAL)
MOTOR SHAFT.....	.750
CONTINUOUS PRESSURE RATING.....	3000 PSI
PORT SIZE	
INLET.....	1 1/16 – 12 (S.A..E. 12)
RETURN.....	1 5/16 - 16 (S.A..E. 16)
CASE DRAIN.....	S.A.E. (4)

RECOMMENDATIONS

MODEL: HYDRO 8KCD-16-3

HIGH PRESSURE LINE 3/4 inch

LOW PRESSURE LINE..... 1 inch

FLOW RATE 16 GPM

*FOR BEST RESULTS KEEP HYDRAULIC OIL
TEMPERATURE BETWEEN 80°F AND 120°F.
DO NOT EXCEED 175°F.*

AN OIL COOLER IS RECOMMENDED.

MAXIMUM BACK PRESSURE 150 PSI

OPEN CENTER 2500 PSI SYSTEMS.

RECOMMEND FILTER 10m

RECOMMEND HYDRAULIC OIL DEXTRON III A.T.F.

RECOMMEND RESERVOIR SIZE..... MINIMUM 30 GAL.

Initial Installation and Start-Up

Be sure you set the hydraulic flow (GPM) to the generator at Approximately 62.5 HZ or 3750 RPM with NO electrical load on the generator.

By using this setting you will have approximately 60HZ (cycles) or 3600 RPM when you are running at full rated load.

One way this can be accomplished is by using a Photo Tachometer on our generator coupling or generator cooling fan.

A Photo Tachometer is an inexpensive tool that can be purchased at McMasters, Grainger, Sears or any other electrical supplier.

INSTALLATION TIPS

Excessive pressure in your return line will damage the hydraulic motor seal. High back pressure can be caused by “spikes” sent back through the return from other equipment on a common return line. Another potential problem can develop if several pieces of equipment are connected to one “common” return line causing a high back pressure (150 PSI is the maximum). We recommend you run the return line from the generator back to the cooling tank with a separate line.

If our hydraulic generator is to be used on a truck or system that will be changing speeds, such as, in a fire truck (pumping water) we suggest you use a load sensing piston type pump rather than a fixed displacement gear type. The system will run much cooler and more efficient.

TROUBLE SHOOTING

PROBLEMS	CAUSES	REMEDIES
ALTERNATOR EXCITATION FAILURE	<ol style="list-style-type: none"> 1. Low Speed 2. Faulty capacitor 3. Faulty winding 	<ol style="list-style-type: none"> 1. Check RPM and set at nominal value. 2. Check and replace. 3. Check that winding resistance is as shown in the tables.
HIGH NO-LOAD VOLTAGE	<ol style="list-style-type: none"> 1. Speed too high. 	<ol style="list-style-type: none"> 1. Check and adjust RPM's
LOW NO-LOAD VOLTAGE	<ol style="list-style-type: none"> 1. Speed too low. 2. Faulty rotary diodes. 3. Breakdown in windings. 	<ol style="list-style-type: none"> 1. Check and adjust RPM's 2. Check and replace. 3. Check winding resistance, as per tables.
PROPER NO-LOAD BUT LOW LOADED VOLTAGE	<ol style="list-style-type: none"> 1. Low loaded speed. 2. Load too large. 3. Rotary diodes short-circuited 	<ol style="list-style-type: none"> 1. Check and regulate RPM. 2. Check and change. 3. Check and replace.
UNSTABLE VOLTAGE	<ol style="list-style-type: none"> 1. Loose contacts. 2. Uneven rotation. 	<ol style="list-style-type: none"> 1. Check connections. 2. Check for uniform rotation speed.
NOISY GENERATOR	<ol style="list-style-type: none"> 1. Broken bearings. 2. Poor couplings. 	<ol style="list-style-type: none"> 1. Replace. 2. Check and repair.

FIXED DISPLACEMENT TYPE GEAR PUMP

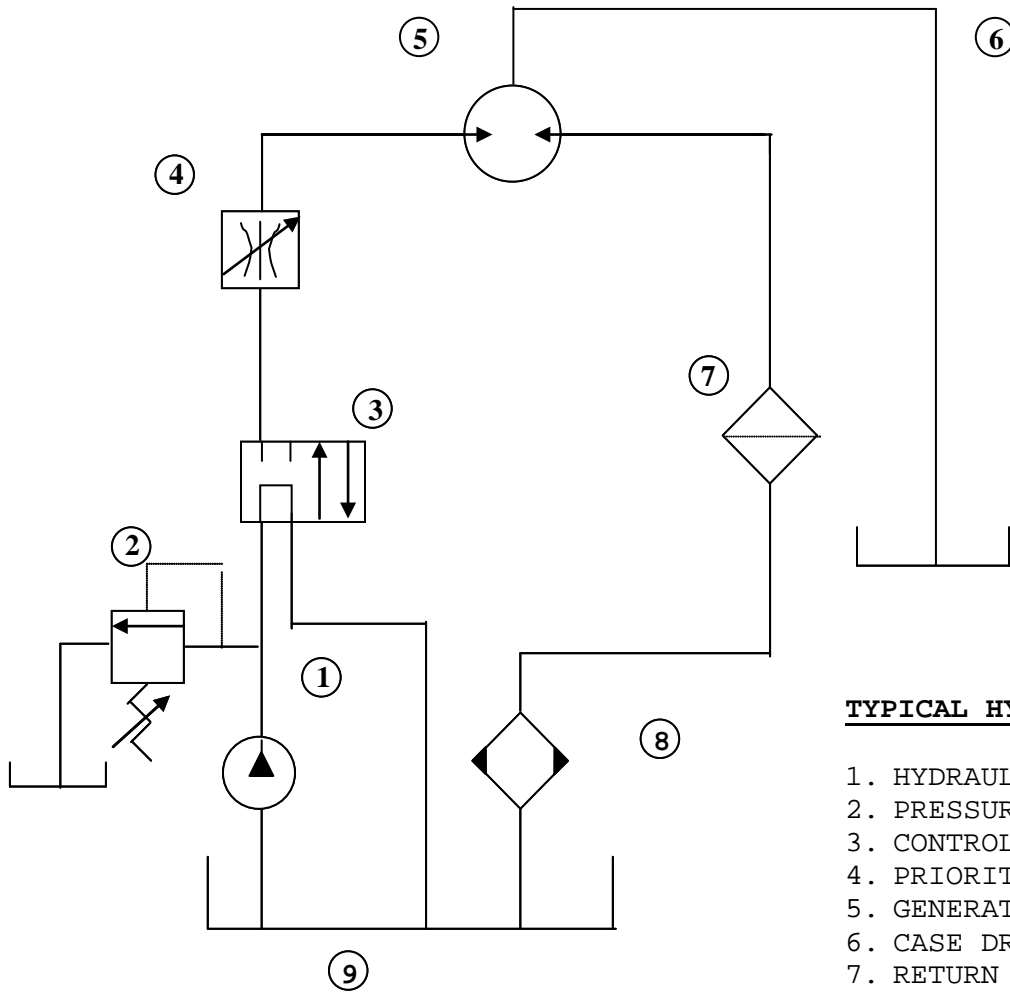

TYPICAL HYDRAULIC SCHEMATIC

1. HYDRAULIC PUMP
2. PRESSURE RELIEF VALVE
3. CONTROL VALVE
4. PRIORITY FLOW CONTROL*
5. GENERATOR HYRAULIC MOTOR
6. CASE DRAIN LINE**
7. RETURN LINE FILTER
8. OIL COOLER
9. HYDRAULIC FLUID RESERVOIR

* Some units may be equipped with integral priority flow control, refer to specific model number.

** External case drain line may be required on some units refer to specific model number.
When external case drain is required it should be unobstructed direct return to reservoir with a minimum I.D. no less than that of case drain port on generator motor.

FOR SPECIFIC INSTALLATION RECOMMENDATIONS CONSULT FACTORY

FABCO BY-PASS FLOW CONTROL

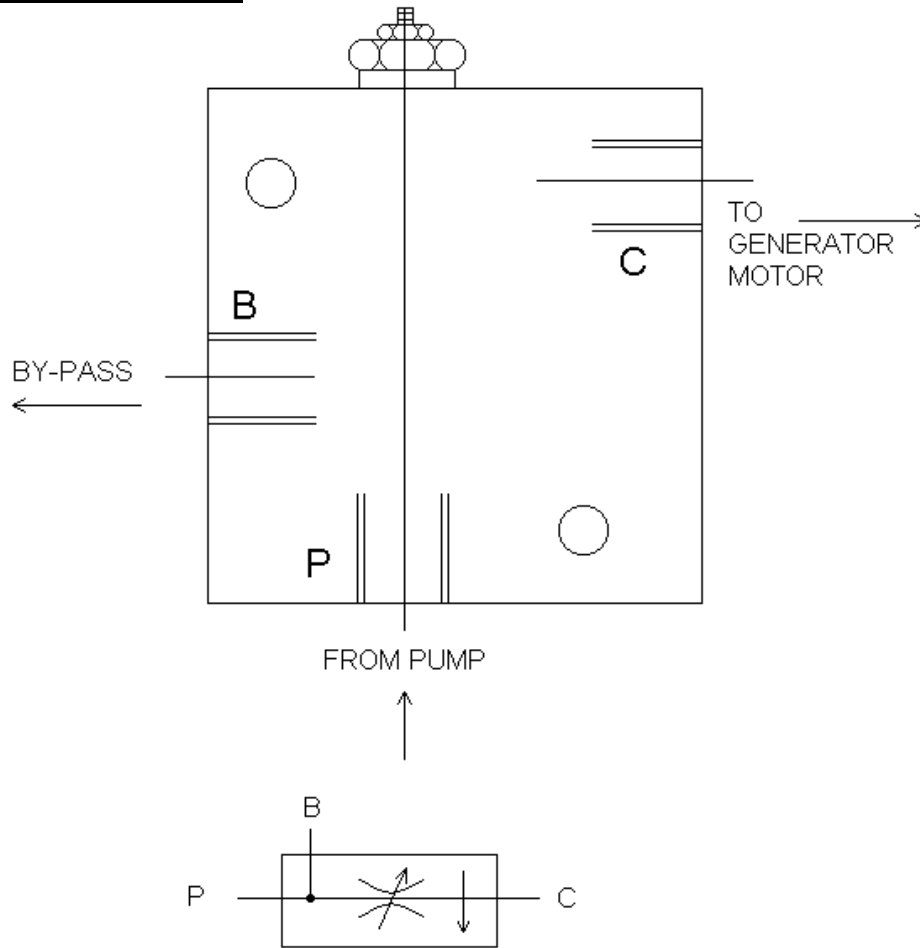

FABCO PN 572233

**NOTE: THIS ASSEMBLY ONLY NEEDED
WITH FIXED DISPLACEMENT TYPE
GEAR PUMP.**

THREE PHASE (Y) CONNECTED 120/208 60 HZ

L-1, L-2 AND L-3 TO NEUTRAL = 120 VOLTS

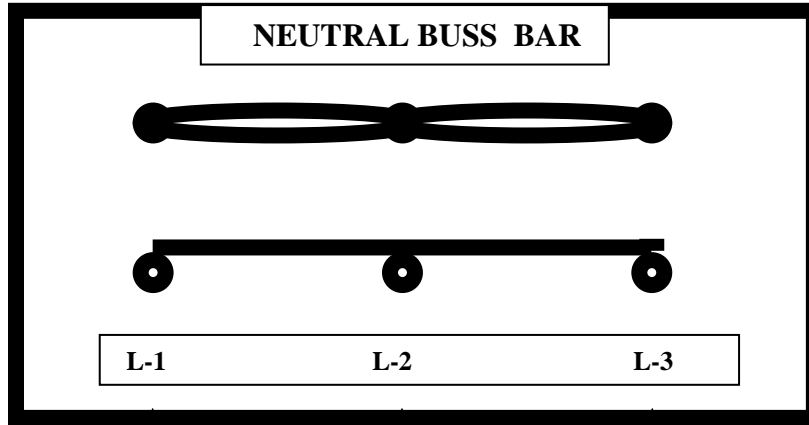

L-1 TO L-2 = 208 VOLTS L-2-TO L-3 = 208 VOLTS L-3 TO L-1 = 208 VOLTS

THREE PHASE DELTA Δ 120 VOLT 60 HZ

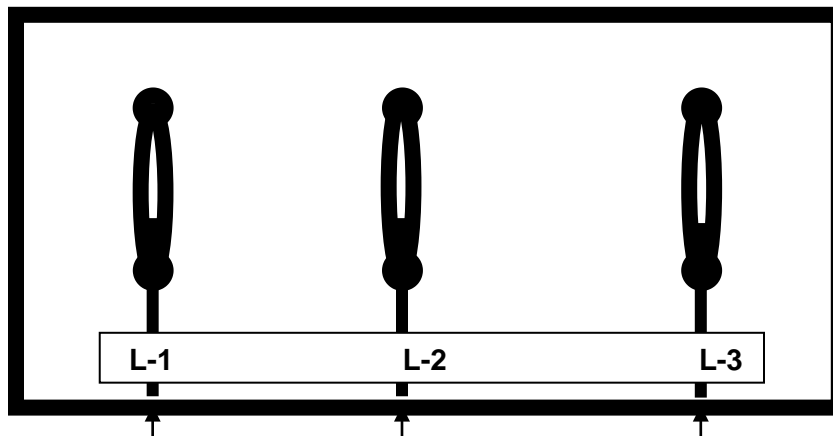

L-1 TO L-2 = 120 VOLTS L-2 TO L-3 = 120 VOLTS L-3 TO L-1 = 120 VOLTS